

版本 REV.	日期 DATE	ECN NO.	变更内容 DESCRIPTION	制图 DRAWN

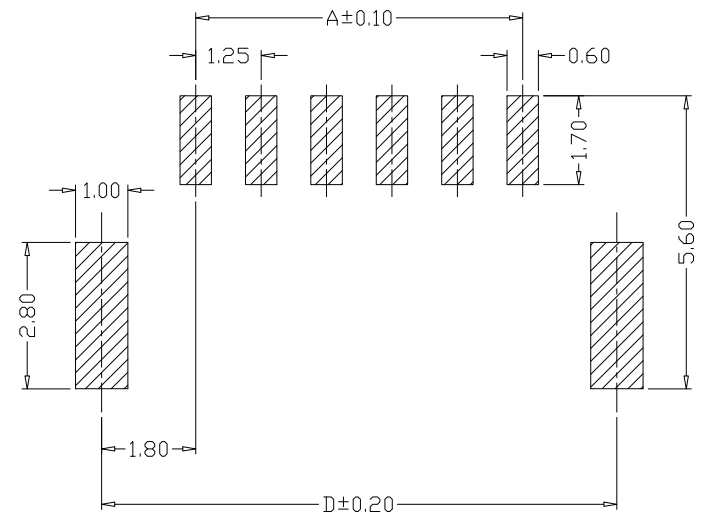

PCB LAYOUT

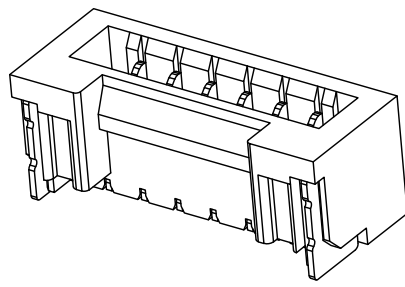
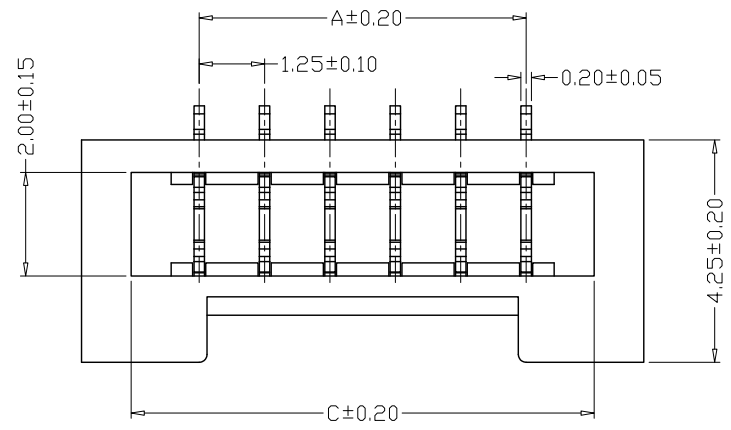
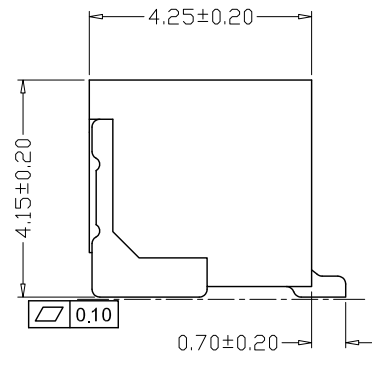
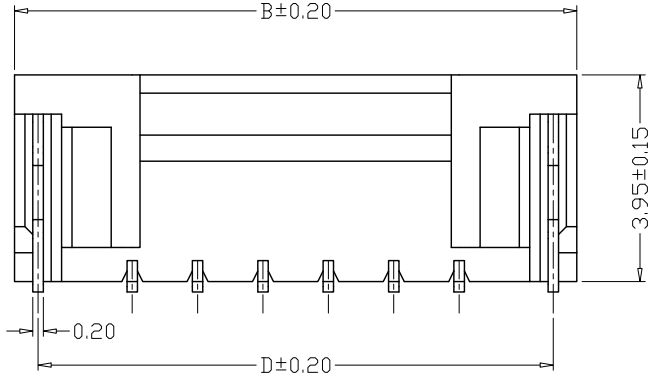

PIN	尺寸 (mm)			
	A	B	C	D
-02AB	1.25	5.75	3.85	4.85
-03AB	2.50	7.00	5.10	6.10
-04AB	3.75	8.25	6.35	7.35
-05AB	5.00	9.50	7.60	8.60
-06AB	6.25	10.75	8.85	9.85
-07AB	7.50	12.00	10.10	11.10
-08AB	8.75	13.25	11.35	12.35
-09AB	10.00	14.50	12.60	13.60
-10AB	11.25	15.75	13.85	14.85
-11AB	12.50	17.00	15.10	16.10
-12AB	13.75	18.25	16.35	17.35

SPECIFICATIONS

- Current Rating: 1.5A AC, DC
- Voltage Rating: 50V AC, DC
- Temperature Range: -25°C~+85°C
- Contact Resistance: 20mΩ Max
- Insulation Resistance: 100MΩ Min
- Withstanding Voltage: 500V AC/minute
- Material
Wafer: LCP UL94V-0
PIN: Phosphor bronze Tin-plated
Solder tab: Phosphor bronze Tin-plated

GENERAL TOLERANCE		制图	张迎春		料号	B12507-nAB		版本	A
X.X±0.25	X.*±2'	DRAWING	2022.08.29		PART NO.	STA1.25立贴		页次	1/1
X.XXX±0.10		审核	钱岳生		TITLE	WAFER SMT TYPE		SHEET	
X.XX±0.20		CHECK	2022.08.29		客户料号				
		核准	张名		CUTM. NO.				
		APPROVAL	2022.08.30		乐清市宏一电子有限公司 YueQing HongYi Electronics Co., Ltd				
		单位	MM	比例					